

BRACKET BH12A

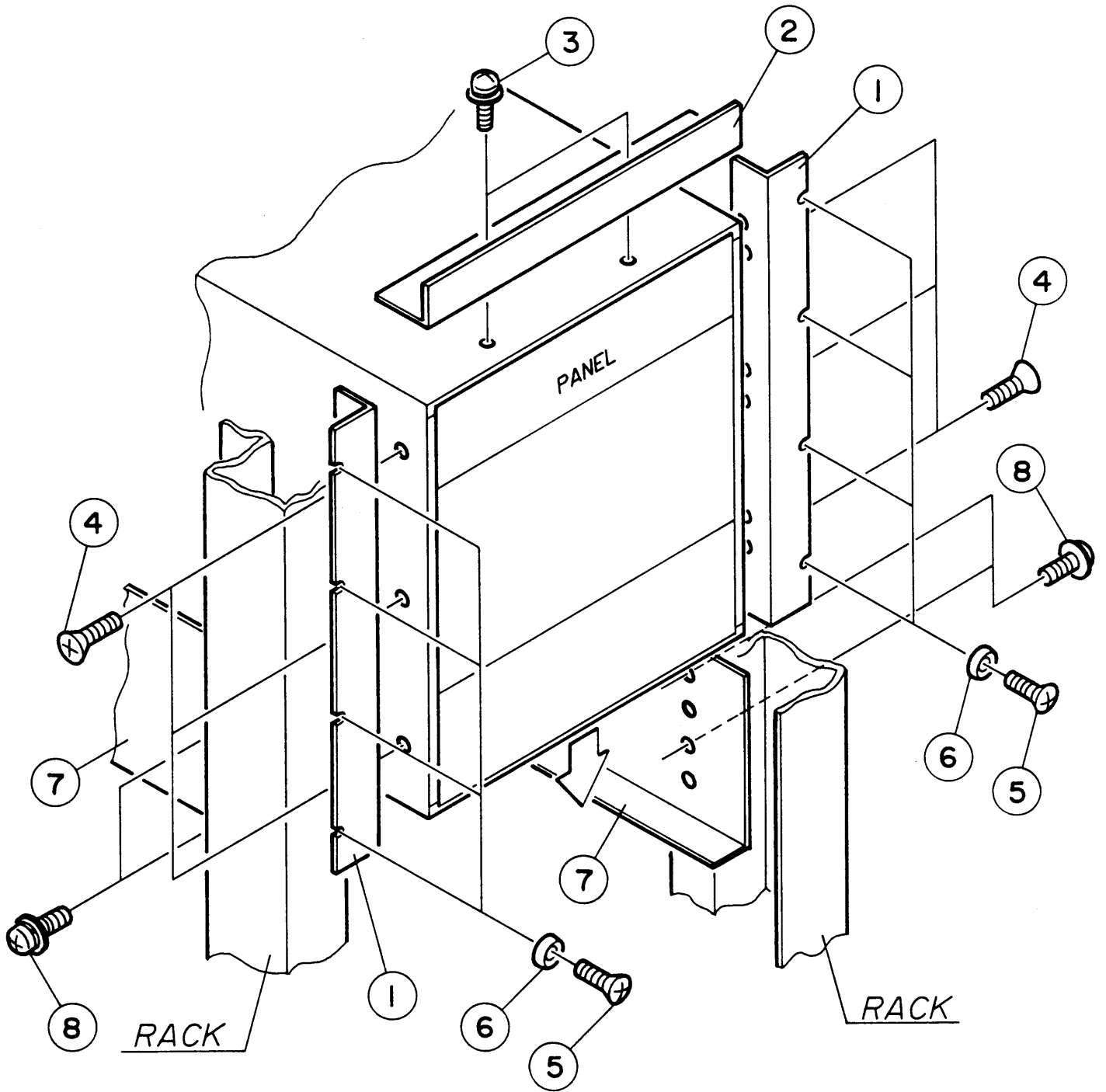

NO.	DESCRIPTION	QTY	CODE NO.
1	BRACKET BH12A	2	D3-988-701
2	BLANK PANEL BH12A	1	A4-988-701
3	SCREW WITH SW,PW M3x0.5x12 S-ZN	2	M3-012-041
4	SCREW,FLAT HEAD M5x0.8x20 S-ZMC2	6	M2-001-451
5	SCREW,OVAL HEAD M5x0.8x14 B-NI	8	M2-002-091
6	FINISHING WASHER 5CW	8	M5-003-031
7	RAIL FOR EXTRA WEIGHT	2	D4-988-701
8	SCREW WITH SW,PW M5 0.8 10 S-ZN	8	M3-012-131